COMMERCIAL INDOOR AIR QUALITY SOLUTIONS

MiracleAir™

High Performance HEPA-Type Air Cleaner



MiracleAir Model CM-12 from Air Quality Engineering, Inc., is the ultimate solution for indoor air pollution capturing both particulate and gaseous contaminants. Odors, tobacco smoke, pollen, dust, vapors and many other irritants are removed by high efficiency, long lasting disposable filters.

Manufacturer and Worldwide Distributor of Air Cleaning Systems for Over 30 Years

TABLE OF CONTENTS

	PAGE
SPECIFICATIONS	3
PLANNING THE INSTALLATION	3
ELECTRICAL INSTALLATION	5
ELECTRICAL SCHEMATIC	6
CHECKOUT	7
MAINTENANCE	7
PARTS LIST & DIAGRAM	9
WARRANTY	10

TECHNICAL SPECIFICATIONS

IMPORTANT!

THE SPECIFICATIONS GIVEN IN THIS PUBLICATION DO NOT INCLUDE NORMAL MANUFACTURING TOLERANCES; THEREFORE, THIS UNIT MAY NOT MATCH THE LISTED SPECIFICATIONS EXACTLY. ALSO, THIS PRODUCT IS TESTED AND CALIBRATED UNDER CLOSELY CONTROLLED CONDITIONS AND SOME MINOR DIFFERENCES IN PERFORMANCE CAN BE EXPECTED IF THOSE CONDITIONS ARE CHANGED. SPECIFICATIONS ARE SUBJECT TO CHANGE WITHOUT NOTICE IN THE INTEREST OF CONTINUING PRODUCT DEVELOPMENT.

ELECTRICAL RATING:

115 Vac, 6.5 Amps, 60 Hz, 208-230 Vac, 4 Amps, 60 Hz

AIRFLOW CAPACITY:

With the standard p/n 41190 95% DOP @ 0.3 micron filter the unit operates on three speeds: Low – 400 CFM, Med – 700 CFM, High – 850 CFM. These are calculated with two of the odor/vapor panels.

DIMENSIONS:

39" L x 22 5/8" W x 13 1/4" H,
90 Lbs. Installed, 115 Lbs. Shipping, add 34 lbs. to the above weights if the optional carbon modules are ordered.

MOTOR:

1/2 Hp, permanent split capacitor, with sealed ball bearings.

BLOWER WHEEL:

Forward curved, direct drive, 12 1/2" x 4", single inlet wheel.

FINE PARTICLE FILTER:

The main particle filter 41190 has a minimum of 102 square feet of media.

PREFILTER:

The standard prefilter is a 1/2" thick washable aluminum mesh, PN 41194. Optional disposable filters are available.

ODOR / VAPOR FILTER:

The standard MiracleAir™ CM-12 comes with 2 disposable activated carbon filters. The deluxe version has two modules, each containing 10 disposable panels for a total carbon weight of 22 lbs.

PLANNING THE INSTALLATION

WARNING!

EXPLOSION HAZARD—Can cause property damage, severe injury or death.

1. Do not install where there is any danger of gas, vapor or dust explosion.
2. Do not install if explosion-proof electrical appliances or fixtures are specified.

APPLICATION & OPERATION

The MiracleAir™ Model CM-12 is designed to be installed on a ceiling where overhead air cleaning is required. Typical applications include offices, designated smoking areas, computer rooms, data processing rooms, etc.

Because it provides its own circulation, the CM-12 may be used in almost any application requiring the removal of airborne contamination from an enclosed

space. The CM-12 must only be used in areas that are ventilated for human occupancy.

MAKEUP AIR

Recommended quantities of clean outdoor ventilation air for various applications are described in Table 2 of

the ASHRAE Standard 62-89, "Ventilation for Acceptable Indoor Air Quality." ASHRAE (American Society of Heating, Refrigerating and Air Conditioning Engineering, Inc., Telephone #404-636-8400) notes that these recommended outdoor air quantities may be reduced by the use of clean, recirculated air if the IAQ Procedure 6.2 is used. Appendix E of ASHRAE 62-89 includes recommendations for the use of clean, recirculated air. However, in most cases, adequate control of carbon dioxide generally requires a minimum clean outdoor air quantity of no less than 15 cubic feet of air per minute per person.

Additional ventilation may be required for toxic contaminants. In any event, the air cleaner must only be used in areas that are ventilated for human occupancy.

SIZING

Air cleaners are generally best sized according to the use of the area and the volume of the room (Air Changes per Hour method).

Secondary factors to consider in applying air cleaners include:

- Type of contamination
- Number of occupants
- Outside air quality
- Anticipated fan setting
- Rate of contaminant generation

By considering these factors, the number of air cleaners required can be adjusted up or down to account for abnormalities in operating conditions.

Follow Steps 1-4 below to determine the number of air cleaners required:

Step 1 – Measure the length, width and height of the room in feet.

Step 2 – Determine the Air Changes per Hour required, ACH. See Chart A.

Step 3 – Determine the CFM (Cubic Feet per Minute of Air). See Chart B.

Step 4 – Enter the figures from Steps 1-3 into the Sizing Formula below and calculate the number of air cleaners required.

CHART A – Air Changes Per Hour		
Load	Description of Application	ACH
Light	General offices & computer rooms	4-5
Avg	Conference and break rooms	6
Heavy	Designated smoking areas, bingo halls, bars & extra smoky areas	8-10

CHART B – Cubic Feet of Air Per Minute		
The air cleaner has a variable speed fan motor. Use the CFM that corresponds to the speed that the air cleaner will operate on normally.		
Low	Medium	High
400	700	850
SIZING FORMULA		
$\frac{L \times W \times H \text{ of Room} \times \text{Air Changes / Hr.}}{\text{CFM of Air} \times 60 \text{ Min.}} = \# \text{ of CM-12's}$		

CHOOSE LOCATION

To ensure even air distribution, the CM-12 draws air into the center of the air cleaner and discharges air in four directions as shown in the figure below. This Coanda airflow pattern ensures that all air in the room passes through the CM-12. See diagram below when mounting the CM-12 to aid the air circulation already

established in the room. When airflow patterns are not immediately apparent, observe the smoke from a cigarette in various locations within the room.

The CM-12 should be mounted on the ceiling near the center of the room. Divide larger rooms into sections and use a CM-12 in the center of each section. In rooms requiring varying levels of air cleaning, concentrate the CM-12 where air cleaning is most required.

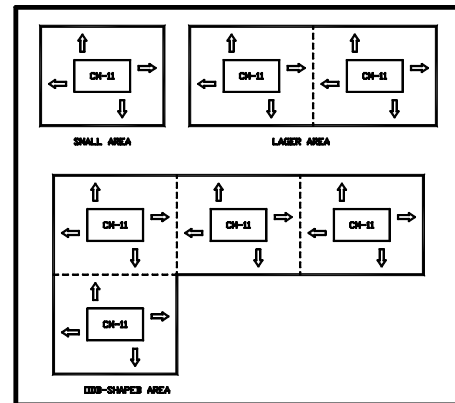

The CM-12 should be installed on the ceiling in nearly all applications. This is especially important when the air cleaner is used for smoke control. Visible smoke contains very small particles, so small in fact, that they are not noticeably affected by gravity. Smoke usually rises to the ceiling and hangs there.

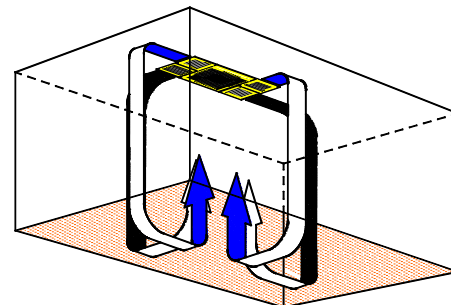

CEILING MOUNTING

The mounting holes in the CM-12 are spaced 16” between centers and 32” between centers to make it easy to fasten the air cleaner directly to the ceiling framework with 3-inch lag screws. Leave a space for the power supply cord to run between the top of the CM-12 and the ceiling. The power supply cord must not be concealed above ceilings or behind walls.

Be sure that you select a strong structural part of the ceiling. Do not fasten it to a false ceiling, plaster or plasterboard. In some cases, it may be necessary to

construct some type of framing strong enough to support the weight of the CM-12.

The CM-12 may also be mounted using 3/8" [10 mm] diameter threaded steel rods available in many hardware stores. Four steel rods will be required.

WIRING

The 120V, 60 Hz CM-12 has a standard three-prong plug on a 10 foot [3 m] power cord. It requires only a standard grounded outlet for electrical power. Route the power cord so that it will be out of the way of the building's occupants.

PERMANENT WIRING

To permanently wire the CM-12, follow these instructions exactly. All wiring must comply with applicable codes and ordinances. Wire the CM-12 using the built-in junction box. It is recommended that No. 14 gauge or heavier wire be used to complete the wiring from the junction box to the external power source. However, be sure to comply with local codes.

1. Open the inlet grille of the CM-12 and remove the primary particle filter by supporting the filter near the turnstiles and rotating the two turnstiles to the open position.

2. Remove the access panel inside the CM-12 cabinet. This panel is the galvanized unpainted

panel on the side the door opens from. This will allow you access to speed control wires.

3. Disconnect and discard the power cord, the solderless connectors and strain relief. Plug the power cord hole with the plug provided.
4. Run conduit from the power supply to the appropriate knockout. Fish wires to the speed control wires in the junction box. Note that you may gain better access to the junction box within the cabinet through the discharge end of the air cleaner. This can be accomplished by removing the discharge louver with a Philips screwdriver and removing the carbon filter.
5. Connect lead wires with solderless connectors including ground (green) wires. Proper grounding of this device is mandatory for correct operation and safety.

ELECTRICAL INSTALLATION

CAUTION!

Persons qualified to install electrical wiring should only attempt this procedure. All wiring must comply with applicable codes and ordinances.

1. **Double check that the rating on the air cleaner is consistent with the power source, either 120 Vac, 60 Hz or 208-240 Vac, 50/60 Hz.**
2. **Run three No. 14 gauge (or heavier) wires through conduit to the wiring compartment on the air cleaner. The green wire should be attached to the external ground. The black and the white wires are the power conductors. The connections are shown in Fig. 2.**

2. Screw the exhaust grille louvers to the air cleaners. This must be done after the carbon filter modules are installed.
3. Install the primary filter so that the airflow arrow points up into the ceiling. Turn the two turnstiles so that they properly support the filter.
4. Hang the intake grille. Position the prefilter and latch the intake grille into place.
5. Clean up the installation area.

REASSEMBLE

1. Install the two carbon filter modules into the two discharge cavities. Make sure the support clips are in place before letting go of the filter modules. **Caution must be used when handling the filter modules. They weigh approximately 40 lbs. when new.**

ELECTICAL SCHEMATIC

AIR CLEANER MODEL CM-12

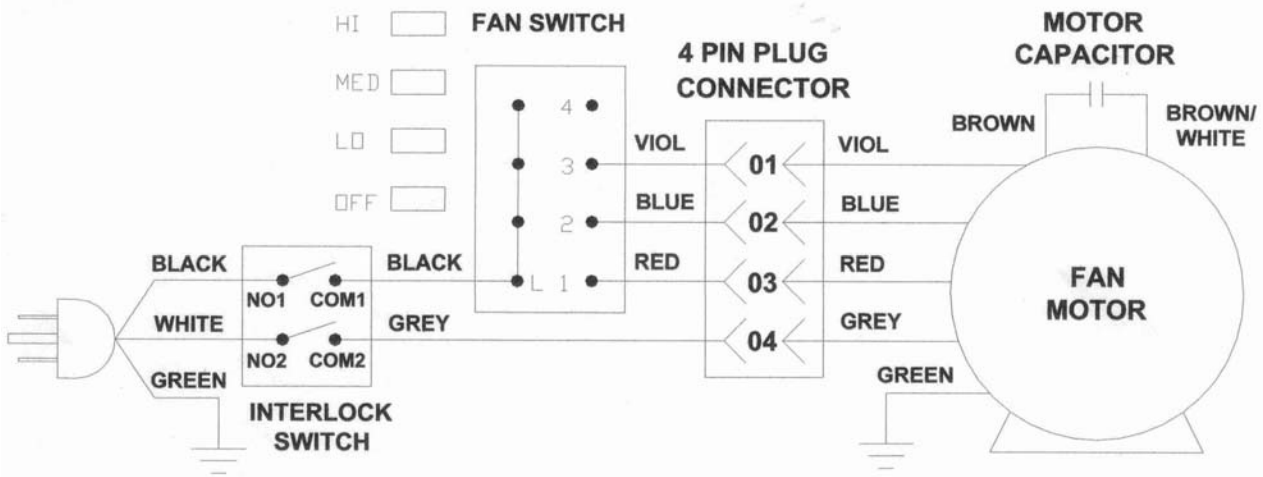

REMOTE CONTROL AIR CLEANER MODEL CM-12

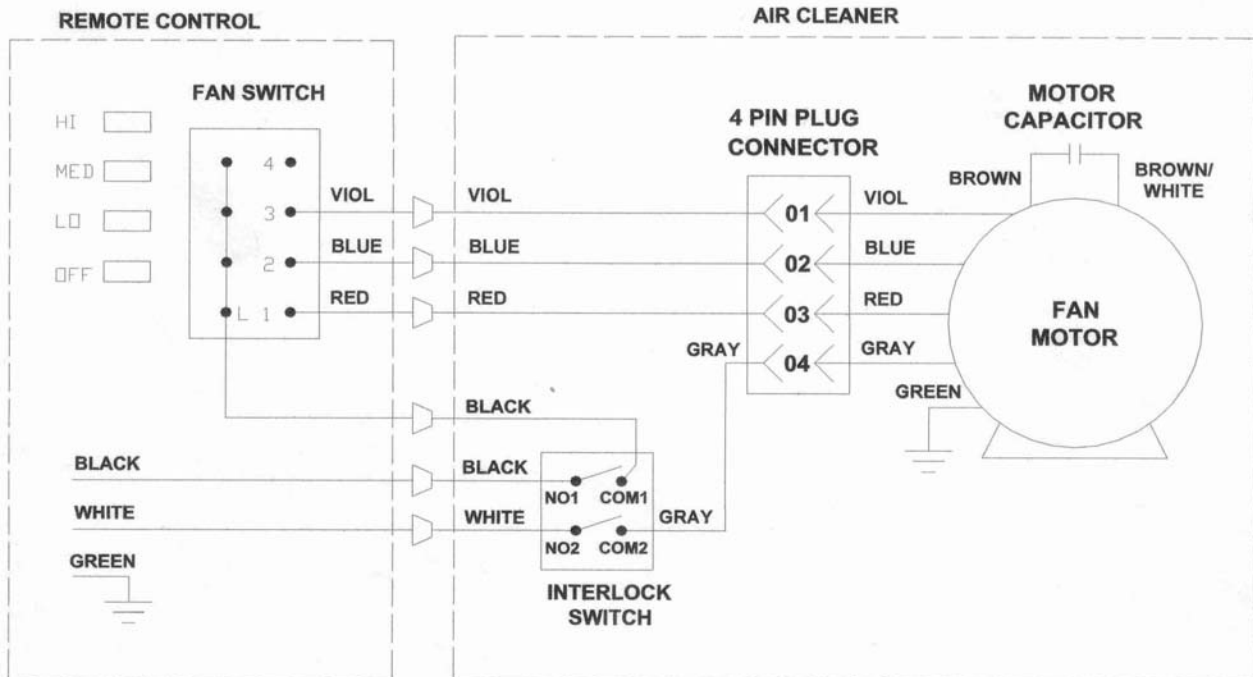

CHECKOUT

Before leaving the installation, check to be sure that the CM-12 is properly installed and operates correctly.

MOUNTING

1. The CM-12 is correctly and securely fastened to the ceiling.
2. It is mounted where it *will not* interfere with normal occupant traffic.
3. Unit is properly oriented for good air circulation.

ASSEMBLY AND OPERATION

1. Be sure that the prefilter, primary particle filter and carbon filters are all properly installed.
2. Be certain the electrical junction box cover is reinstalled.
3. Turn the air cleaner on using the knob near the intake grille. Make sure that the blower energizes and creates airflow into the intake grille.

MAINTENANCE

CAUTION!

1. **The power must be shut off before servicing the filters.**
2. **When servicing the air cleaner, stand on a stable work platform or ladder.**

FREQUENCY OF FILTER MAINTENANCE

The MiracleAir™ Model CM-12 is designed to have a very long filter maintenance interval. This is accomplished because of the large volume of media used in both the particle filter and the odor/vapor module. See the Specifications section for details.

The exact maintenance interval is determined by the specific application of the MiracleAir™ unit. In an office application, the prefilter could require cleaning every 2-3 months. The primary particle filter may last 1-2 years and the odor/vapor filters should be replaced every 6 to 9 months in the standard unit.

Because of the different variables with each application, it is recommended that the prefilter be inspected every two weeks during the first couple of months of operation. When there is a noticeable accumulation of dust and dirt, clean the filter. After inspecting the unit for a one or two month time period, you will have established the proper cleaning interval for the prefilter. When the MiracleAir™ unit no longer removes odors from the air, it is time to replace the disposable filters within the odor/vapor modules. When there is a noticeable reduction in airflow with the

prefilter clean, it is time to replace the primary particle filter. It is a good idea to keep track of how long a period of time the primary particle filter and odor/vapor

filters lasted so that you can anticipate how long the new filters will last. The first filters will likely require changing sooner than subsequent filters due to dust that may have settled in areas with poor air circulation as well as furniture and walls off-gassing from previous exposure to higher levels of contamination.

Please note that your MiracleAir™ unit is equipped with a variable speed controller. If you are running your unit on medium blower speed, you can increase the blower speed to compensate for the filter plugging with contaminant. If you are operating your unit on the maximum speed setting and your airflow is reduced, you will need to replace the primary particle filter.

CLEANING THE PREFILTER

The prefilter is removed from the air cleaner by opening the intake grille. Push the two buttons on the grille and guide the grille to the open position, the grille will hang down towards the floor on its hinges.

Shake out or vacuum the accumulated contaminants from the prefilter. If necessary, the prefilter can be soaked in an alkaline detergent solution. Do not soak in an acid detergent solution or use high-pressure water, air or steam to clean the prefilter. Doing so will damage the prefilter and shorten its life.

REPLACING THE PARTICLE FILTER

The particle filter is removed from the air cleaner by:

1. Opening the intake grille.

2. With one hand supporting the filter near the turnstiles, rotate the two turnstiles to the open position.
3. Remove the filter from the unit and discard. It can not be vacuumed, washed or reverse air blasted.
4. **Be extremely careful when handling the new filter. A damaged filter will compromise the air cleaning efficiency.**

REPLACING THE ODOR/VAPOR FILTERS OF CM-12 STANDARD UNITS

The standard MiracleAir™ Model CM-12 comes with two disposable filters that must be replaced on a periodic basis. These filters are located at the exhaust ends of the air cleaner just inside the discharge grilles.

1. Remove both of the discharge louvers. This requires a Philips screwdriver. Handle the louvers with care.
2. Remove the odor/vapor filters by sliding them out from the discharge ends of the air cleaner. The filters are resting in tracks inside the cabinet. There is no locking mechanism to release.

REPLACING THE ODOR/VAPOR FILTERS OF THE CM-12 DELUXE UNITS

The standard MiracleAir™ Model CM-12 comes with two VOC filters that must be replaced on a periodic basis. These filters are located at the exhaust ends of the air cleaner just inside the discharge grilles.

1. Remove both of the discharge louvers. This requires a Philips screwdriver. Handle the louvers with care.
2. Remove the odor/vapor filters by sliding them out from the discharge ends of the air cleaner.
3. Place the filter module on a tabletop or workbench. Unscrew the two thumbscrews and remove the retaining bracket. Slide the ten disposable filter panels out of each module and replace with the new filter panels.
4. Slide the odor/vapor filter back into the air cleaner until it hits the stops in back.
5. Replace the discharge louvers and make sure they are securely fastened.

PARTS LIST AND DIAGRAM

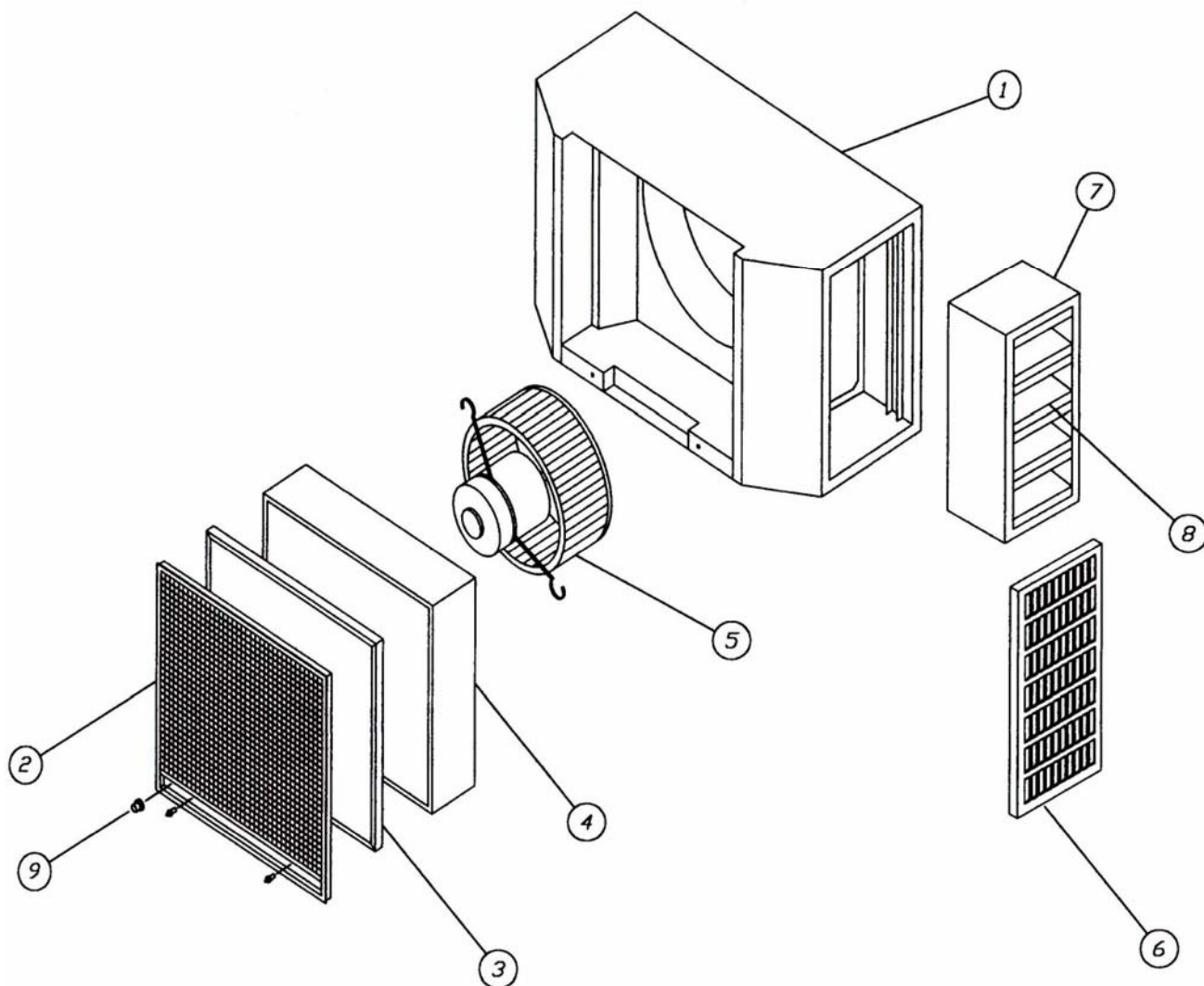

Item number	Description	Part number
1	Cabinet	05512
2	Grille Assy	05519
3	Alum mesh prefilter	41194
4	Main Filter	41190
5	Motor Assy with Blower	41190
6	Louver Grille	21906
7	Carbon Module, includes frame & 10 filters (2 Required)	41193
8	Disposable Filter Kit, includes 20 disposable filters for two PN 07163	07163
9	Control Switch	05050

CERTIFICATE OF WARRANTY

3-YEAR LIMITED WARRANTY

Air Quality Engineering, Inc., warrants to the original purchaser, subject to the conditions below, that should the product covered by this warranty ("Product") fail to perform by reason of improper workmanship or material, Air Quality Engineering, Inc., ("AQE") will, during the period of three (3) years from the date of original purchase, either, (i) replace the Product or (ii) provide all necessary parts to repair the Product, without charge. The decision to replace the Product or the necessary parts shall rest solely with AQE. This 3-year limited warranty does not apply to main filter elements. Air Quality Engineering, Inc., will replace without charge the main filter elements during the period of thirty (30) days from the date of original purchase if the main filter elements fail to perform by reason of improper workmanship or material. This warranty is valid only under the following conditions:

CONDITIONS

1. **AUTHORIZATION:** Purchaser will contact Air Quality Engineering, Inc., 800-328-0787, for authorization, returned goods authorization number (RGA) and shipping address. AQE will direct purchaser to either return the necessary parts or the Product at AQE's option.
2. **PROPER DELIVERY:** The shipping, freight prepaid, or delivery of the parts or the Product to Air Quality Engineering, Inc., in either its original carton or in a carton assuring similar protection of the Product with returned goods authorization number (RGA) clearly displayed on the outside of the carton.
3. **UNAUTHORIZED REPAIR:** A showing by the original purchaser that the Product has not been altered, repaired or serviced by anyone other than an authorized service technician using genuine AQE parts.
4. **UNAUTHORIZED PARTS:** A showing by the original purchaser that the Product has had only genuine Air Quality Engineering, Inc., parts and filters used in its operation and maintenance.
5. **SERIAL NUMBER INTACT:** A showing by the original purchaser that the Serial Number has not been altered or removed.
6. **MISUSE:** A showing by the original purchaser that the Product has not been involved in an accident, freight damaged, misused, abused or operated contrary to the instructions contained in the Owner's Manual.

Air Quality Engineering, Inc.'s, sole responsibility shall be to repair or replace the Product within the terms stated above. AQE shall not be liable for any consequential damages resulting from any breach of warranty, express or implied, applicable to this Product. Some states do not allow the exclusion or limitation of consequential damages so this limitation may not apply to you.

THIS WARRANTY IS IN LIEU OF ALL OTHER WARRANTIES, EXPRESS OR IMPLIED, AND THE WARRANTIES OF MERCHANTABILITY AND FITNESS FOR A PARTICULAR PURPOSE ARE HEREBY EXCLUDED BEYOND THE THREE -YEAR DURATION OF THIS WARRANTY. Some states do not allow limitations on how long an implied warranty lasts so the above limitation may not apply to you.

This warranty gives you specific legal rights and you may also have other rights that vary from state to state.

**AIR QUALITY ENGINEERING, INC.
7140 NORTHLAND DRIVE NORTH
MINNEAPOLIS, MINNESOTA 55428-1520**

**TOLL FREE: 800-328-0787
TELEPHONE: (763) 531-9823
FAX: (763) 531-9900**

MANUFACTURER & WORLDWIDE DISTRIBUTOR OF SMOKEMASTER® AIR CLEANING SYSTEMS